



Technical documentation

Fire protecting fronts «System TI» EI 30-RF 1

VKF Nr. 32'977

Version März 2024

WW Brandschutzfronten GmbH
Talgasse 7
5503 Schafisheim

info@brandschutzfronten.ch
Tel: +41 62 891 85 03
www.brandschutzfronten.ch

Table of contents

1.	Introduction	4
1.1	About	4
2.	Arrangement options	5
2.1	Views Arrangement options without panels (type 1-3).....	5
2.1.1	Single-leaf shaft fronts (Type 1)	5
2.1.2	2-leaf shaft fronts (Type 2)	5
2.1.3	Infinite Arrangements (Type 3).....	6
2.2	Infinite arrangements with plinths and panels (type 5).....	6
2.3	Ground plans	7
2.4	Seitenschnitt.....	7
3.	Description of execution	8
3.1	Fittings.....	9
3.1.1	Hinges B 120.....	9
3.1.2	Hinges B 180.....	9
3.1.3	Fire safety lock	10
3.1.4	Door closer.....	11
3.1.5	Reed kontakt	11
4.	Detail drawings	12
4.1	Ceiling connections (side sections)	12
4.1.1	With surrounding frieze	12
4.1.2	With panel up to 230mm	12
4.1.3	With panel up to 880mm, visibly screwed on	13
4.1.4	With panel up to 880mm, hooked in.....	13
4.1.5	Gliding ceiling connection.....	14
4.2	Horizontal details (ground plans).....	15
4.2.1	With surrounding frieze	15
4.2.2	Center post for infinite arrangement.....	15
4.2.3	Center detail for 2-leaf doors.....	16
4.2.4	With panel up to 230mm	16
4.2.5	Visible side mounted up to 740mm	17

4.3	Floor connections (side sections)	18
4.3.1	With surrounding frieze	18
4.3.2	Plinth 50-150mm	18
4.3.1	Without frieze	19
4.3.2	Plinth460mm (only for 1-leaf single arrangement).....	19
5.	Additional information	20
5.1	Soft bulkhead Intumex CSP	20
5.2	Can boxes Agro.....	20
5.3	Additional soundproofing requirements	21
5.3.1	Sound 1, Rw 32 dB	21
5.3.2	Sound 2, Rw 34 dB	21
5.3.3	Sound 3 Rw 36 dB	21
5.4	Frame joints.....	22

1. Introduction

Are you looking for a tested fire protection front that is EI 30-RF 1 approved in Switzerland?

We offer you a comprehensive range with many different details. All fronts are made to measure according to your wishes. Subsequent insertion of additional cables is possible because the fronts are designed to be removable.

The TI shaft fronts are made of 25 mm gypsum fiberboard and offer a wide range of options. They can be supplied with a sliding ceiling connection, visible sides, a plinth as well as side and top panels. The panels can be either demountable or screw-fixed. Partitions and box cut-outs are also available. You can choose hinges with an opening of 120 degrees or 180 degrees. Door closers and a reed contact can be added as an option. You can also obtain optional sound insulation overlays for the shaft fronts.

1.1 About

- Tested to EI 30-RF 1 in accordance with VKF approval
- Suitable for installation in single-sided planked shaft walls, LBW, MBW or Lignum EI 60 walls
- All fronts can be dismantled
- Sliding ceiling connection
- Narrow center sections
- Hinges open 120 degrees
- Hinges open 180 degrees
- Soft bulkhead
- Box bulkhead
- Sound insulation
- Door closer
- Reed contact

2. Arrangement options

2.1 Views Arrangement options without panels (type 1-3)

2.1.1 Single-leaf shaft fronts (Type 1)



Installed in MBW- LBW or Lignum EI 60 wall:

1-leaf clear dimension Max. Width 1200mm, Max. Height 2900, Max. area 3,67m²

In shaft wall, planked on one side EI 60

1-leaf clear dimension Max. Width 1200mm, Max. Height 2600, Max. area 2,82m²

2.1.2 2-leaf shaft fronts (Type 2)

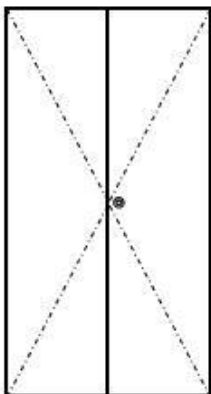

Installed in MBW- LBW or Lignum EI 60 wall:

2-panel clear dimension Max. Width 2400mm, Max. Height 2900, Max. area 6,79m²

Planked on one side in shaft wall EI 60

2-panel clear dimension Max. Width 2400mm, Max. Height 2600, Max. area 6,10m²

2.1.3 Infinite Arrangements (Type 3)

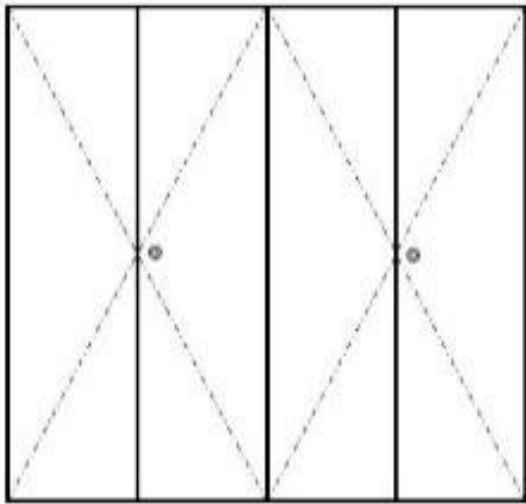

Installed in MBW- LBW or Lignum EI 60 wall:

Max. clear dimension height 2900mm single and double-leaf units can be arranged endlessly..

In shaft wall, planked on one side EI 60

Max. clear dimension height 2600mm Single and double-leaf elements can be arranged endlessly in a row

2.2 Infinite arrangements with plinths and panels (type 5)

Max. Unit height 3433 mm incl. panel and plinth

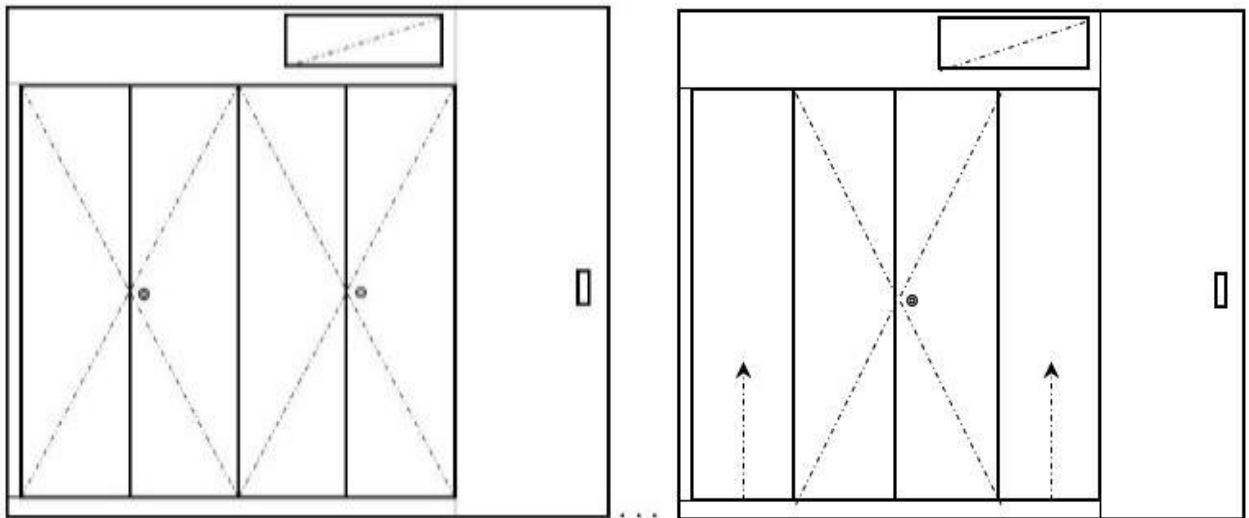

Installed in MBW- LBW or Lignum EI 60 wall:

1-leaf clear dimension Max. Width 750mm, Max. Height 2450, Max. Area 1,67m²

2-leaf clear dimension Max. Width 1500mm, Max. Height 2450, Max. area 3,48m²

Score points with additional locking mechanism:

1-leaf clear dimension Max. Width 1200mm, Max. Height 2900, Max. area 3,67m²

2-leaf clear dimension Max. Width 2400mm, Max. Height 2900, Max. area 6,79m²

Plinths, fronts and panels

Plinth:

Dimensions Max. Width infinite, Max. height 150mm

Visible sides hooked in or visibly screwed:

1-leaf clear dimension Max. Width 740mm, Max. Height 3400, Max. area 2,32m²

Panels hooked in or visibly screwed:

1-leaf clear dimension Max. Width endless, Max. Height 880mm

Fixed panels

Dimensions Max. Width endless, Max. Height 200mm

Fixed support joints:

Max. Width 200mm

2.3 Ground plans

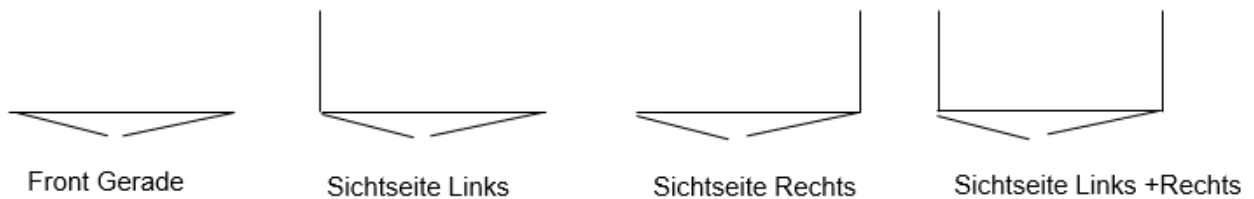

2.4 Seitenschnitt



Front Gerade

3. Description of execution

Our TI type fire protection fronts are made of RF 1 gypsum fiberboards, which are finished on both sides with a synthetic resin surface in multi-layer laminate. The surface structure has a fine hammer finish and the fronts are white. The panel thickness is approx. 26 mm. The edges are edged with matching ABS edging. Various surface options are available on request, including color variants from our collection, primer laminates, veneered or lacquered surfaces.

The frame consists of four-sided friezes with a cross-section of 90/26.6 mm. The corner joints are screwed together. A self-adhesive foaming strip with a cross-section of 10/2.5 mm is attached all around the frame frieze. Retaining plates for the hinges are attached to the frame. The base plates are arranged to match the door leaf. A striker block and a striking plate for the bayonet bolt are attached to the top and bottom of the cross frieze on the lock side (only for double-leaf fronts).

Two to three hinges are used for each door leaf. On the lock side, an espanolette lock with rod and catch hook striker is used. For double-leaf doors, a striking bar and two bayonet bolts are mounted on the inactive leaf. A self-adhesive foaming strip with a cross-section of 10/1.5 mm is attached to the narrow side in the middle.

3.1 Fittings

3.1.1 Hinges B 120

Chrome steel hinges 3D adjustable,
Opening angle 120 degrees.

Securing the hinge in the middle

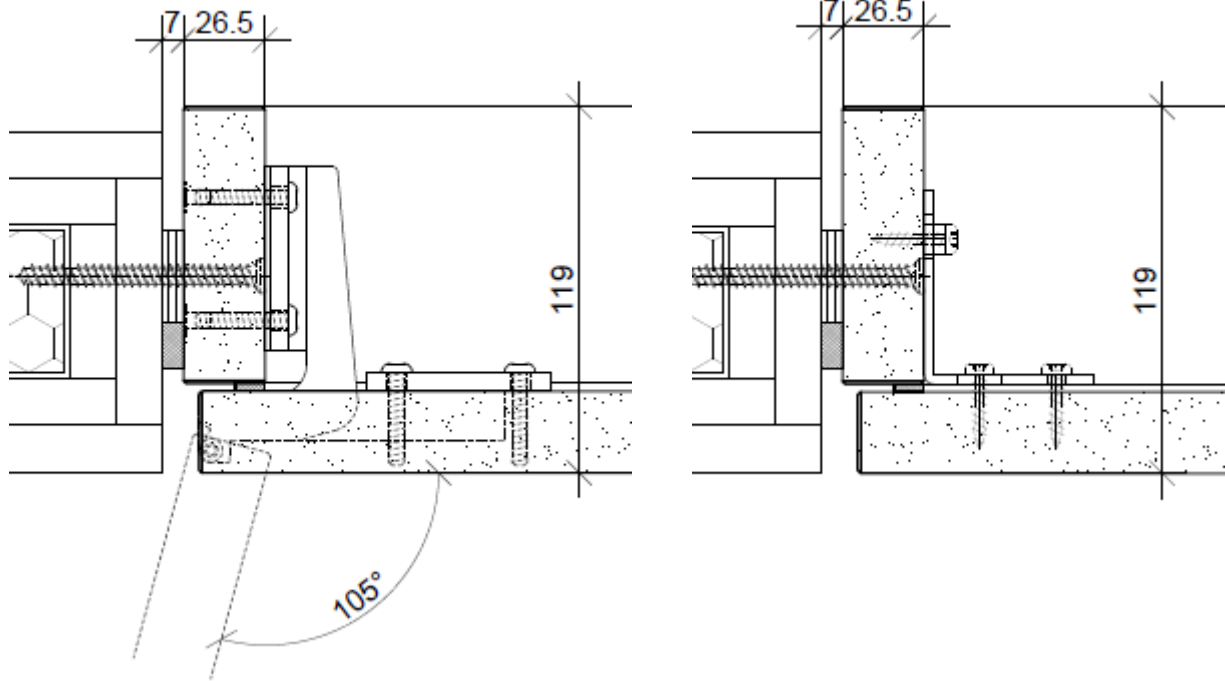

3.1.2 Hinges B 180

Chrome steel hinges 3D adjustable, opening angle 180 degrees

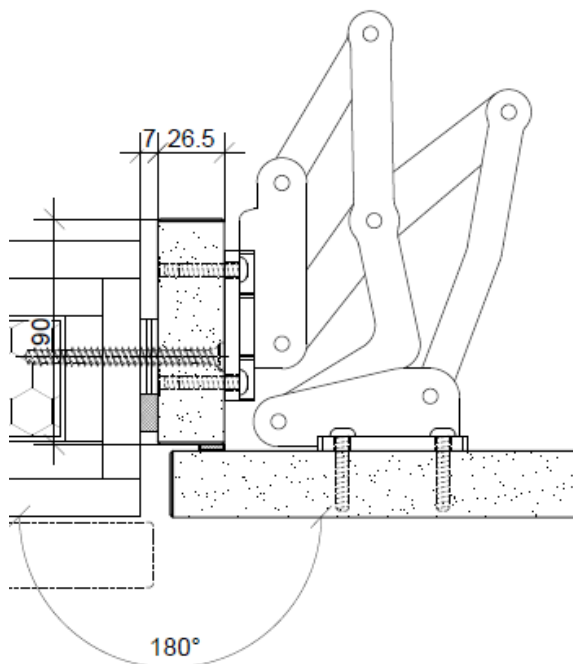

3.1.3 Fire safety lock

- Basic version combination sleeve with square

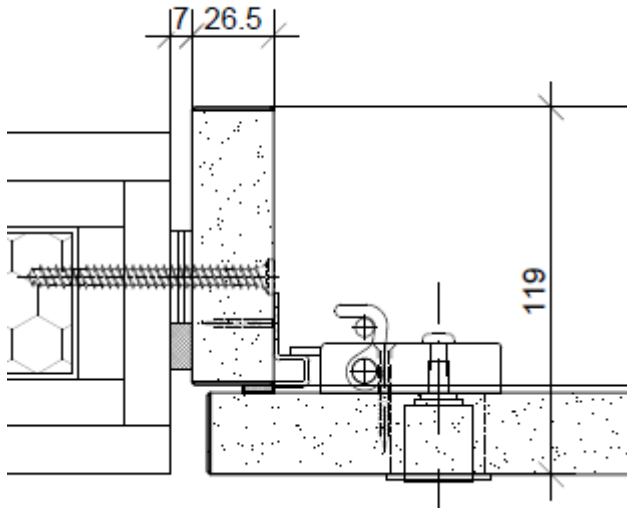

Design options:

- Combination sleeve with for on-site cylinder
- without combination sleeve with square
- without combination sleeve with cylinder

3.1.4 Door closer

Door closer screwed on internally, color silver e.g. Geze 3000 V

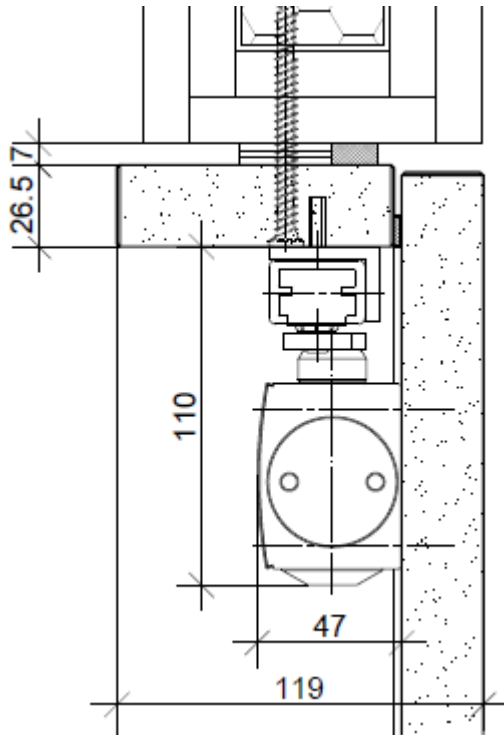

3.1.5 Reed kontakt

Screw-on magnetic contacts e.g. EffEff 10360-6

4. Detail drawings

4.1 Ceiling connections (side sections)

4.1.1 With surrounding frieze

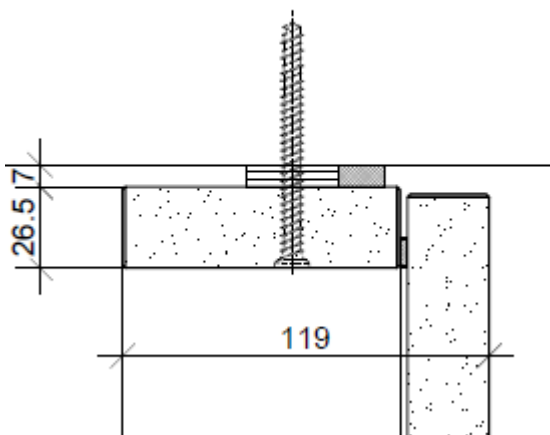

4.1.2 With panel up to 230mm

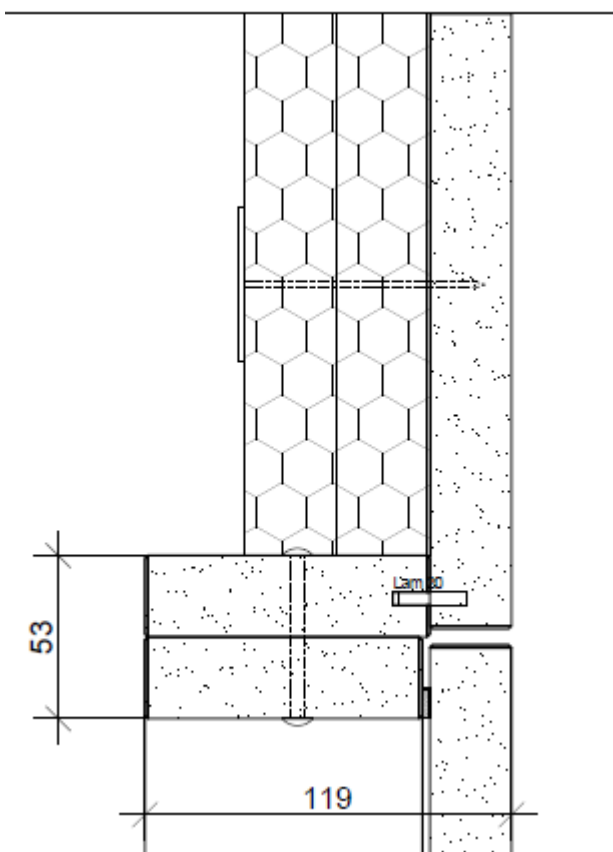

4.1.3 With panel up to 880mm, visibly screwed on

The panels are visibly screwed from the front using a combination of hanger bolts and round nuts. This ensures that the covers are always removable.

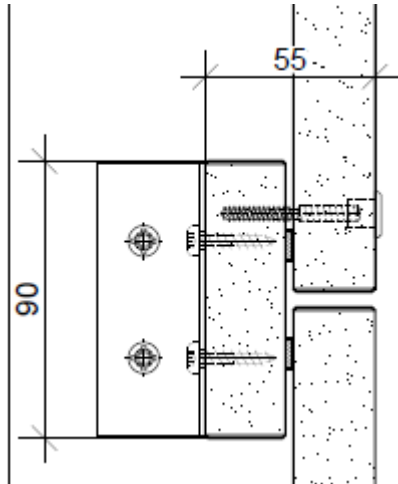

4.1.4 With panel up to 880mm, hooked in

The panels are hung in with suspension fittings. The upper frieze is doubled with this solution. This ensures that the panels can always be dismantled.

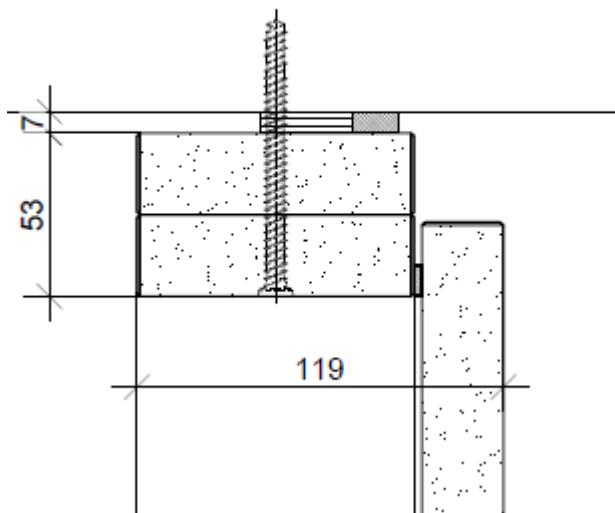

4.1.5 *Gliding ceiling connection*

The gliding ceiling connection is the ideal design for prestressed ceilings or wall constructions. Deflections of up to 13 mm can be accommodated at height.

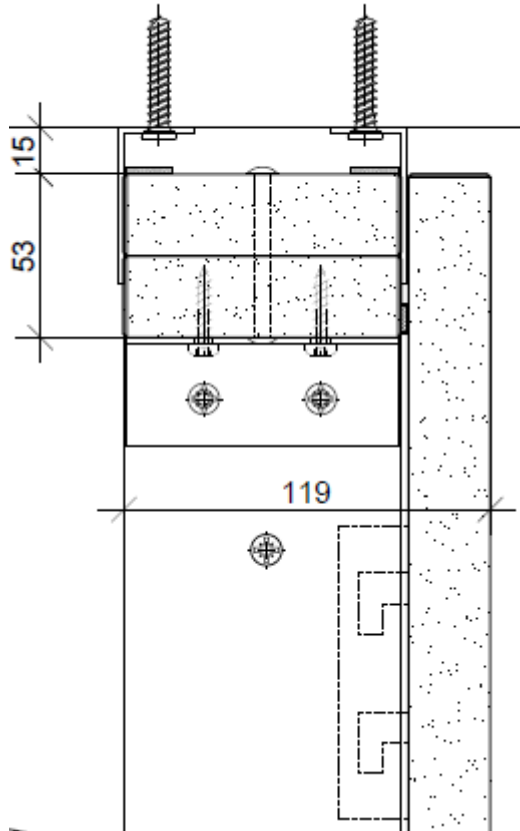

4.2 Horizontal details (ground plans)

4.2.1 With surrounding frieze

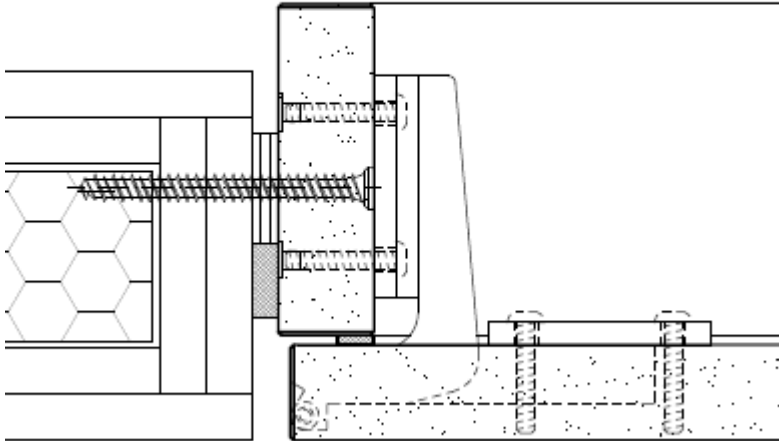

4.2.2 Center post for infinite arrangement

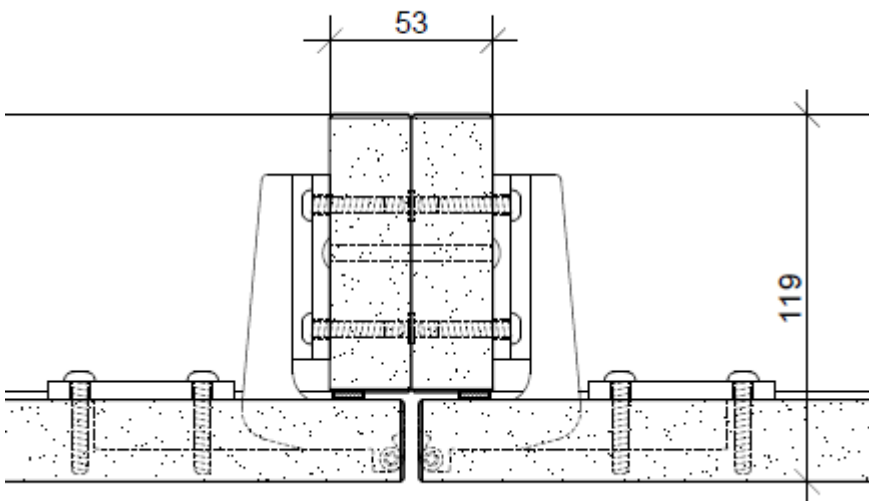

4.2.3 Center detail for 2-leaf doors

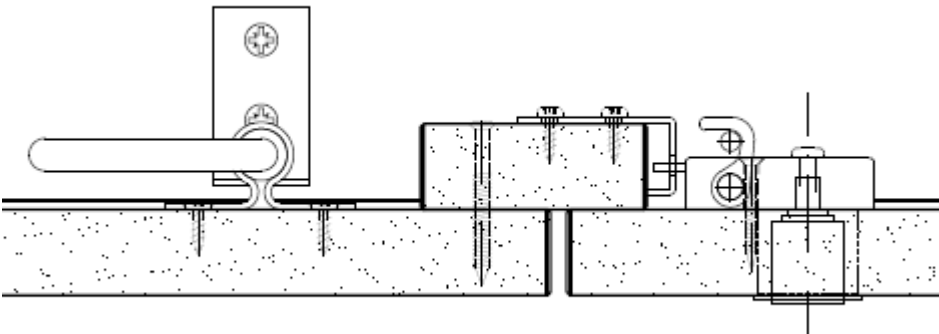

4.2.4 With panel up to 230mm

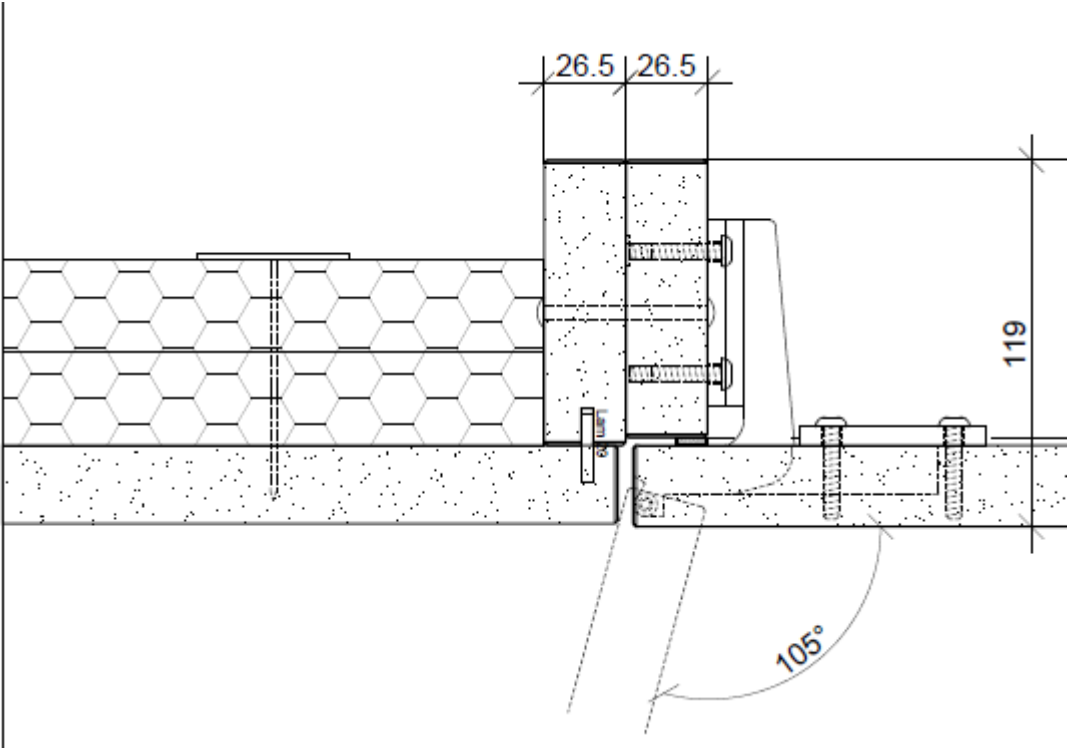

4.2.5 Visible side mounted up to 740mm

The visible side is mounted to the wall with mounting brackets at a maximum distance of 660 mm. In the front area, the screw connection is made with 5/45mm panhead screws at a maximum distance of 660mm. Possible gaps are filled with rock wool.

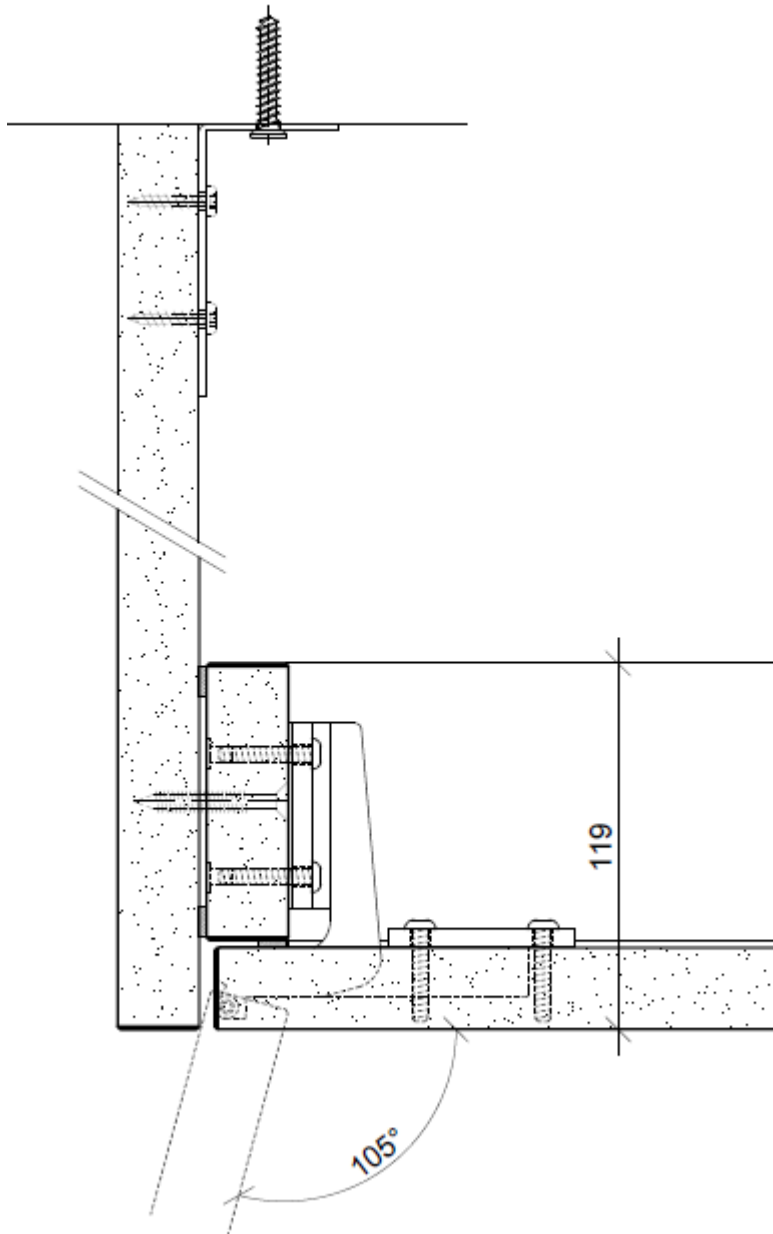

4.3 Floor connections (side sections)

4.3.1 With surrounding frieze

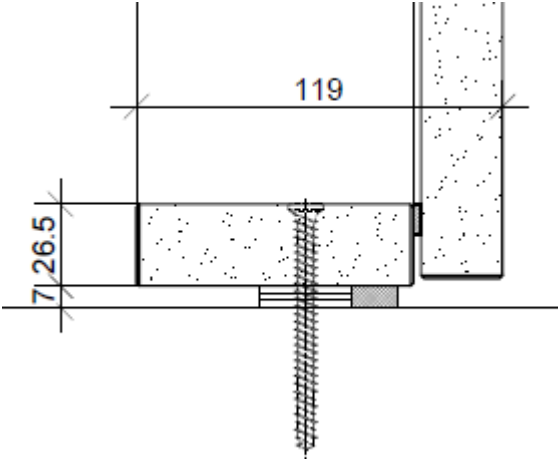

4.3.2 Plinth 50-150mm

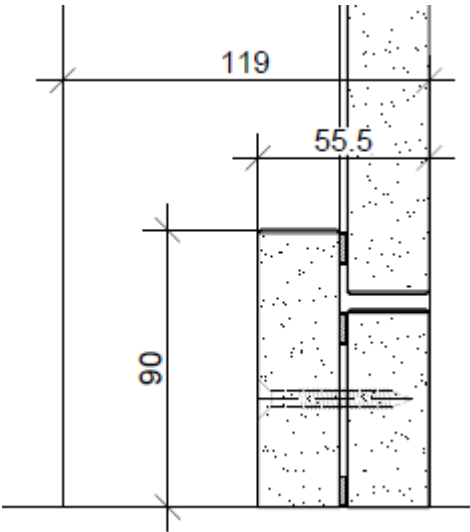

4.3.1 Without frieze

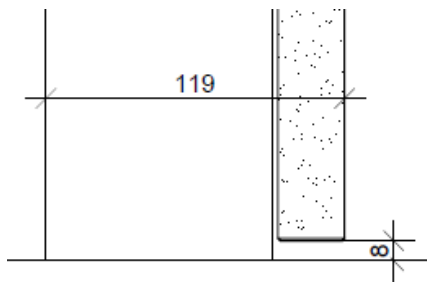

4.3.2 Plinth 460mm (only for 1-leaf single arrangement)

The pre-assembly is mounted to the floor with mounting brackets at a maximum distance of 660 mm and to the wall with two pieces. Any gaps are filled with rock wool.

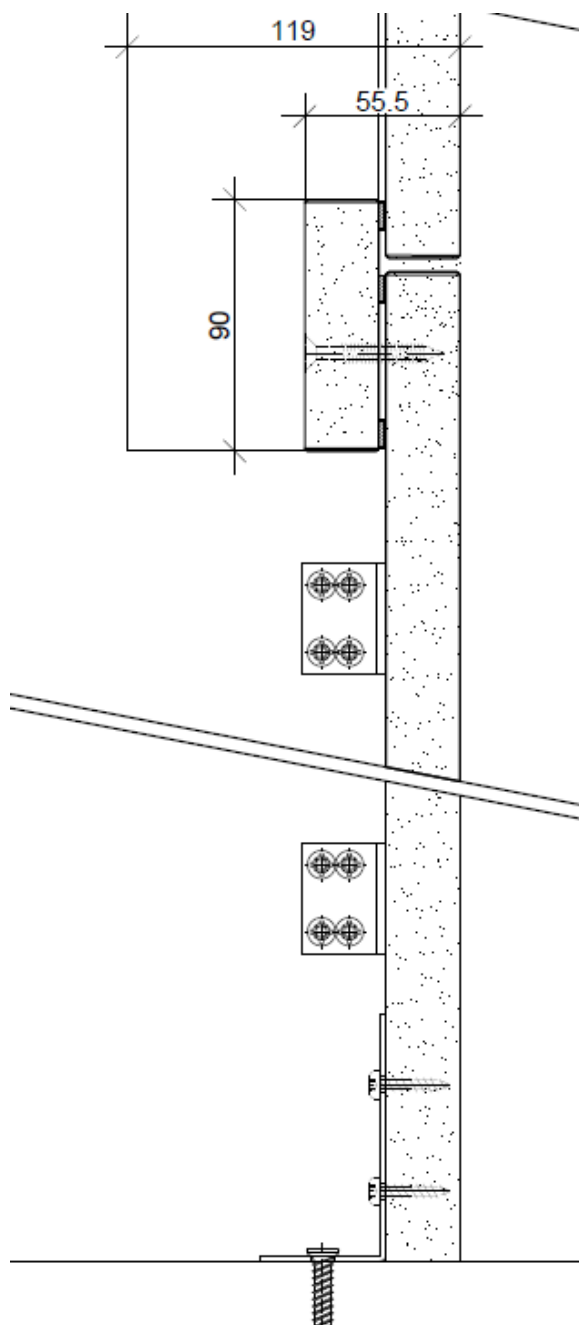

5. Additional information

5.1 Soft bulkhead Intumex CSP

The Intumex CSP soft bulkhead can be installed horizontally in the cover up to a size of 800/450 mm. The cover must be doubled in the area of the connection.

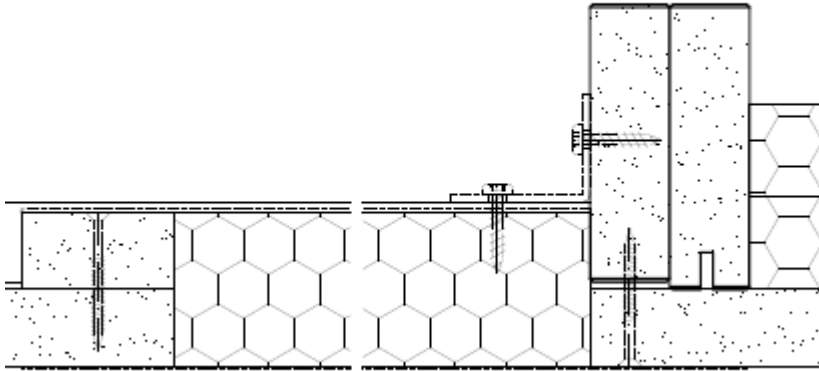

5.2 Can boxes Agro

Quickbox Maxi HWD 90 2x1

Art.-Nr.: 9499-77.02
E-No.: 372632609
VKF-Zulassung: 26831 & 26846

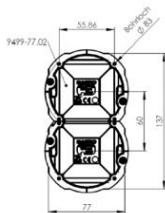

Options:

- Quickbox Maxi HWD 90 1 x 1
- Quickbox Maxi HWD 90 2 x 2

These may be fitted in all panels. No height specification necessary.

5.3 Additional soundproofing requirements

Door fronts and panels are doubled with 30 to 50 mm rock wool. Silicone seals are fitted on all four sides.

In order to comply with the sound values, it is required that the seals are cut and bonded optimally in the miter cut. The specified sound insulation value was calculated in accordance with EN ISO 717, whereby the spectrum adjustment value C is -1 dB.

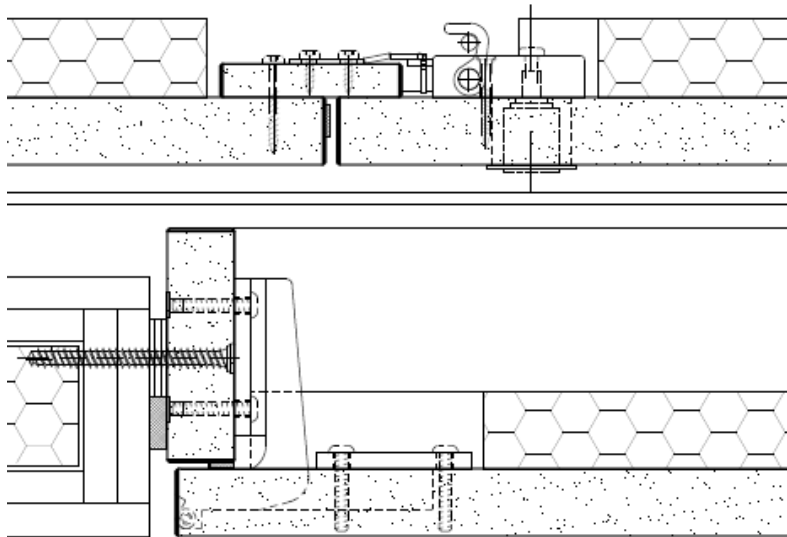

5.3.1 Sound 1, R_w 32 dB

Fitted with silicone seal

5.3.2 Sound 2, R_w 34 dB

Fitted with silicone seal and 30 mm rock wool

5.3.3 Sound 3 R_w 36 dB

Fitted with silicone seal and 50 mm rock wool

5.4 Frame joints

Screw fittings

Rahmenverbindung
(Ansicht von oben)



Option:

- Screwed with angle bracket

